

132 balancing valve

with flow meter



132 balancing valve with flow meter



Introduction

Balancing valves are required in heating and chilled water systems to help achieve the correct flow rate through the designated circuit in the system, calculated by the system designer.

The system designer calculates the required flow rate for each heat emitter or cooling coil to ensure a comfortable room temperature is maintained.

Balancing valves, when regulated, force water from the most favoured to the least favoured circuits to achieve the design flow rate confirmed by measuring the actual flow rate.

A correctly balanced system is essential to achieve the design specification, thermal comfort and minimum energy consumption.

Design

The Altecnic 132 balancing valve has a flow meter, for direct reading of the regulated flow rate, housed in a bypass on the valve body which is normally isolated during normal operation.

The flow meter allows fast and easy balancing of the circuit without the need to attach a monometer or differential pressure gauge.

Supplied with female parallel threaded ends complying with BS EN ISO 228-1.

Patent application No. MI2007A000703

Construction Details

Component	Material	Grade
Valve		
Body	Brass	BS EN 12165 CW617N
Ball	Brass	BS EN 12164 CW614N
Ball control stem	Brass - chrome plated	BS EN 12164 CW614N
Ball seat	PTFE	
Position indicator	PSU	
Seals	EPDM	
Flow Meter		
Body	Brass	BS EN 12165 CW617N
Caps	Brass	BS EN 12164 CW614N
Disc- stem	Brass - chrome plated	BS EN 12164 CW614N
Spring	Stainless steel	
Seals	EPDM	
Flow meter float	PSU	
Indicator cover	PSU	

Technical Specification

Medium:		water, glycol solution
Max. percentage of glycol:		50%
Max. working pressure:		10 bar
Working temperature range:		-10 to 110°C
Unit of measurement:		l/m
Accuracy:		±10%
Rotation of ball valve:		90°
Operating wrench:	½" to 1¼"	9 mm
	1½" & 2"	12 mm

Dimensions

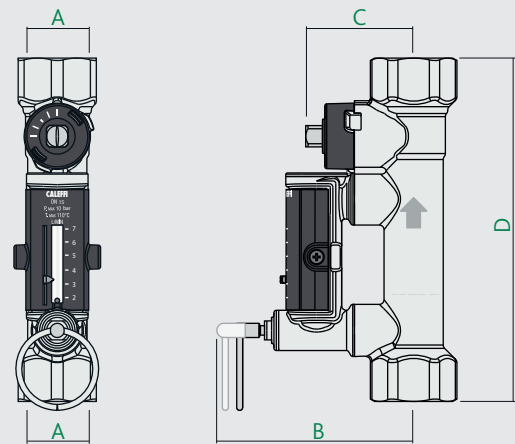

Size	A	B	C	D	kg
132402	G½	84	46	145	0.80
132512	G¾	84	46	145	0.74
132522	G¾	84	46	145	0.74
132602	G1	85	47	158	0.96
132702	G1¼	88	50	164	1.19
132802	G1½	91	57	171	1.47
132902	G2	97	62	177	2.00

Construction Details

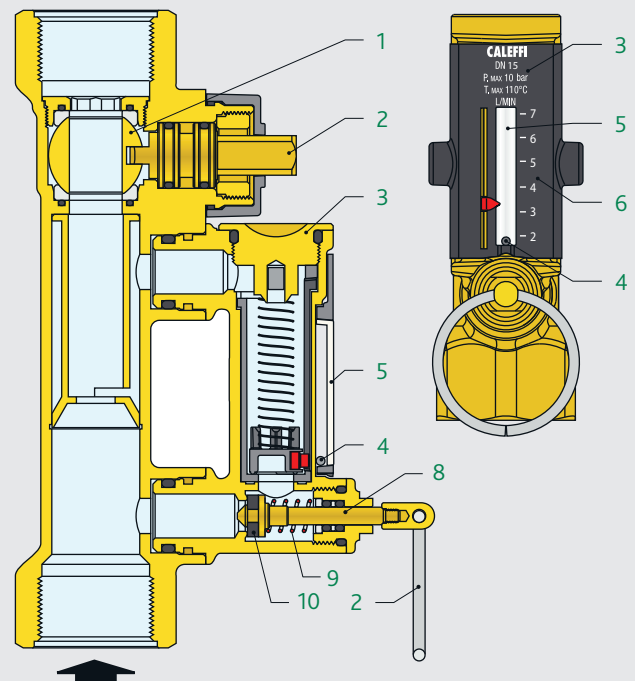

The valve regulates using the ball (1), operated by the control stem (2)

The flow rate is measured using the flow meter (3) housed in a by-pass on the valve body, which is normally isolated.

The flow rate value is indicated by a metal sphere (4), sliding within a transparent guide (5), marked alongside by a graduated scale (6).

132 balancing valve with flow meter

Flow Meter Operation

The flow meter measures the flow when the stem-disc assembly (8) is pulled away from the valve using the ring (2).

This lifts the disc facing (10) away from its seat and opens the bypass allowing the water to flow through the flow meter.

When the ring (2) is released, the spring (9) automatically closes and isolates the flow meter returning the valve to its normal function.

Ball - Magnet Indicator

The ball (4), that indicates the flow rate value, is not in direct contact with the liquid passing through the flow meter.

The ball (4) slides up and down in a cylinder (5) that is actually separate from the body of the flow meter.

The ball is moved by a magnet (6) fixed to a spring loaded piston (7) which returns automatically to the zero flow indication.

This means that the flow rate indicator remains perfectly clean and provides reliable readings over time.

Isolation and Flow Regulation

The valve can be operated from fully closed to fully open..

A slot on the end of the control stem indicates the status of the valve.

When the control stem is turned fully clockwise and the slot lies perpendicular to the axis of the valve, the valve is fully closed.

When the control stem is turned fully anti-clockwise and the slot lies in line with the axis of the valve, the valve is fully open.

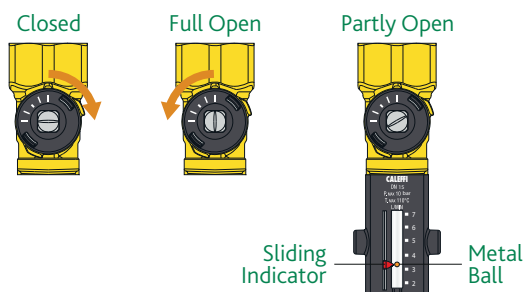

To regulate the flow, firstly with the aid of the sliding indicator, mark the reference flow rate to which the valve requires setting.

Using a suitably sized spanner on the operating square of the control stem of the valve rotate until the design flow rate is achieved.

This is indicated by the metal ball that runs inside the transparent guide.

Kv Value and Flow Rates

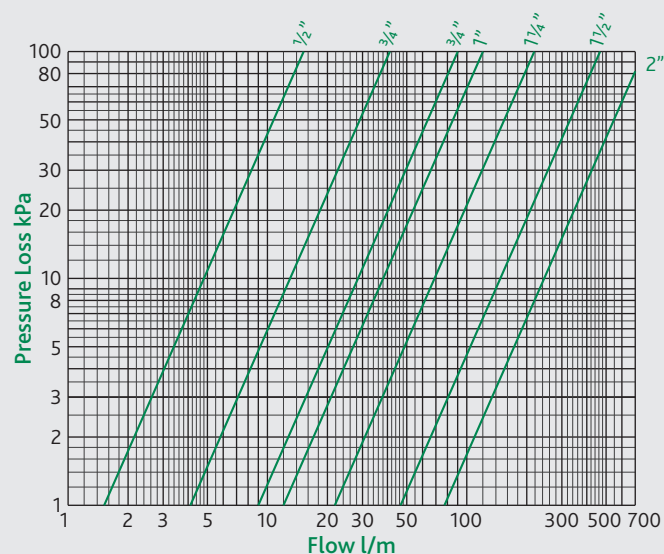

Code	Size	Flow rates		Kv
		l/m	l/s	
132402	1/2"	2 to 7	0.033 to 0.116	0.9
132512	3/4"	5 to 13	0.083 to 0.216	2.5
132522	3/4"	7 to 28	0.117 to 0.466	5.4
132602	1"	10 to 40	0.167 to 0.666	7.2
132702	1 1/4"	20 to 70	0.333 to 1.166	13.1
132802	1 1/2"	30 to 120	0.5 to 2.0	27.8
132902	2"	50 to 200	0.833 to 3.333	46.4

Kv value with valve full open

E & O.E

Altecnic Ltd Mustang Drive, Stafford, Staffordshire ST16 1GW

T: +44 (0)1785 218200 E: sales@altecnic.co.uk

Registered in England No: 2095101

altecnic.co.uk

AL 076 22-08-16

altecnic
Caleffi group